







# Instruction manual

## *Pocket – Tester*





## Table of contents

	Data sheet	3
	Product description	4
	Instructions for pH1 / Conductivity 1	6
	Calibration procedure	7
	Instructions for pX4 / pH5-Food / ORP5 / Cond5 / PC5 / PC6	8
	Calibration procedure	9
	ERRORS DESCRIPTION	12

# Data sheet

	Basic pH Pocket-Tester (pH 1)	Basic Conductivity / TDS Pocket-Tester (Cond. 1)	Advanced pH / mV / Temp. Food Pocket-Tester (pH 5 food)	Advanced pH / ORP / Temp. Pocket-Tester (pX 4)	Advanced ORP / Temp. Pocket-Tester (ORP 5)	Advanced Conductivity / TDS / Salt. / Temp. Pocket-Tester (Cond. 5)	Advanced pH / mV / Cond. / TDS / Salt. / Temp. Pocket-Tester (PC 5)	Advanced pH / mV / ORP / Cond. / TDS / Salt. / Temp. Pocket-Tester (PC 6)
<b>pH measuring range</b>	0-14	-	-2 - 16		-	-	-2 - 16	
<b>Resolution</b>	0,1 / +0,2	-	0,01 / +00,2		-	-	0,01 / +0,02	
<b>Points of calibration</b>	1 - 2	-	1 - 3		-	-	1 - 3	
<b>Buffers</b>	3 USA	-	5 USA		-	-	5 USA	
<b>mV measuring range</b>	-	-	- 1000... + 1000 mV		-	-	- 1000... + 1000 mV	
<b>Resolution</b>	-	-	0,1 / 1		-	-	0,1 / 1	
<b>mV (ORP) measuring range</b>	-	-			- 1000... + 1000 mV	-	-	- 1000... + 1000 mV
<b>Resolution</b>	-	-			0,1 / 1	-	-	0,1 / 1
<b>Points of calibration</b>	-	-			1 defined by the user	-	-	1 defined by the user
<b>Conductivity measuring range</b>	-	0,01µS - 199,9	-	-	-	0,01µS - 199,9 mS		
<b>Resolution</b>	-	Automatic scale / +2 % fs	-	-	-	Automatic scale / +2 % FS		
<b>Points of calibration</b>	-	1 - 2	-	-	-	1 - 3		
<b>Temperature coefficient</b>	-	1,91 %/°C	-	-	-	0,00 - 4,00%/°C		
<b>Reference temperature</b>	-	25 °C	-	-	-	20 / 25 °C		
<b>TDS measuring range</b>	-	0,01ppm - 199,9 ppt	-	-	-	0,01 ppm - 199,9 ppt		
<b>TDS factor</b>	-	0,40 - 1,00	-	-	-	0,40 - 1,00		
<b>Salinita measuring range</b>	-	-	-	-	-	0,01 mg/l - 100,0 g/l		
<b>Temperature range</b>	0 - 60°C (nv)		0 - 60 °C					
<b>Resolution</b>	-		0,1 / +0,2°C					
<b>Measure unit</b>	°C / °F							
<b>System indication</b>	-		Si		-		Si	
<b>Auto Off</b>	After 8 minutes							
<b>Display</b>	LCD		3 color LCD backlight display					
<b>IP-protection</b>	IP 67							
<b>Power supply</b>	2 x 1,5V AAA batteries							

### KEYPAD







Pocket-Tester Advanced  
 pX 4 / pH 5-Food / ORP 5 / Cond 5 / PC 5 / PC 6







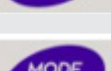

Pocket-Tester Basic  
 pH 1 / Cond 1

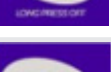

#### Keypad Functions for Tester pX 4 / pH 5-Food / ORP 5 / Cond 5 / PC 5 / PC 6

Button	Function	Action
	 ESC	Press to switch on/off the meter. Press to escape from setup menu or calibration procedure.
	*	During measurement: Press to turn on/off the back light.
	MODUS 	During measurement: Press to switch between pH -> mV (pH) -> mV (ORP) -> Cond -> TDS -> SAL During Setup: Press to scroll in the menu or increase the value of the selected parameter.
	CAL 	During measurement: press to start the calibration of the selected parameter. Press to confirm the calibration and setup value.

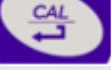
#### Keypad Functions for Tester pH 1 / Cond 1

Button	Function	Action
		Press to switch on/off the meter.
		During Setup: Press to scroll in the menu or increase the value of the selected parameter.
	CAL 	During measurement: press to start the calibration of the selected parameter. Press to confirm the calibration and setup value.

## DISPLAY

The device is endowed with LCD display for Series 1; 3 colors backlight LCD for Series 4, 5 und 6.

- **GREEN:** Setup or measurement mode
- **BLUE:** Calibration mode
- **RED:** Error/Alarm

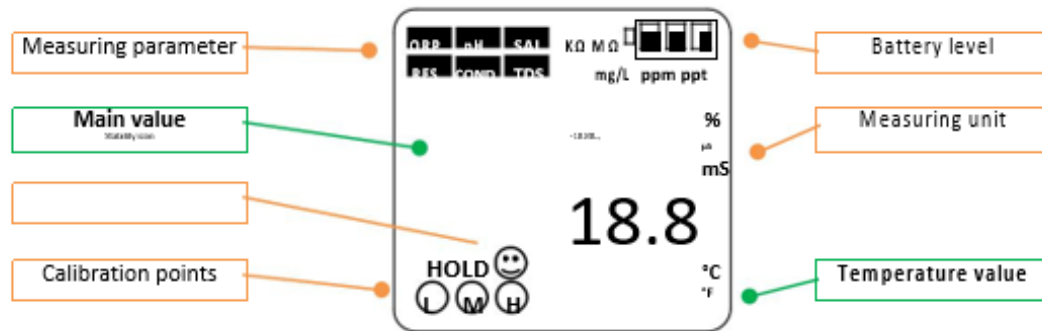

## CALIBRATION POINTS INDICATOR

When a calibration is performed these icons indicate the points calibrated. The instruments mentioned are supplied with a 475 mV solution.

Icon	Working range	pH - mode	Conductivity mode
○	Low	4,01 pH	84 μS
○	Medium	7,00 pH*	1413 μS
○	High	10,01 pH	12,88 μS

\*First point for pH calibration is always 7.00 pH

**Note:** ORP calibration on pX4, ORP5 and PC6 instruments is possible on only 1 point definable by the user.

## POWER SUPPLY

These testers use 2 x 1.5V AAA alkaline batteries (already supplied).

Make sure to insert the batteries in the correct direction, following the silk-screened indications on the transparent body of the Tester itself.

- Properly dispose of waste batteries according to current legislation.
- Replace all batteries together with batteries of the same type.

## POWER ON

Press  key once, the meter will switch On and the display will show all the segments active for 2 sec.

Then it will display the following:

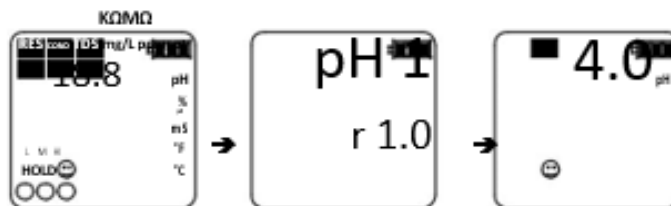







All segments ON -> model name + software release -> measurement

## POWER OFF

To turn off the meter press  key for 3 seconds, the meter will switch off.

## SETUP-MENÜ FOR PH1 / CONDUCTIVITY 1

1. With the meter turned off, press and hold the **CAL** key and press  once.
2. The meter will switch on with all the segments active, release **CAL** key, the meter will go into the Setup Menu.
3. The display will show SLT on primary display with **COND** flashing (only for Cond1).
4. Press  to select the parameter between COND or TDS to be used for measurements and press  to confirm (Only for Cond1). Only if the TDS is selected then the display will show TDS Fct flashing, press  to change this factor and then press  to confirm (Only for Cond1).
5. The display will show rSt (RESET): nO flashing.
6. Press  and select **YES** if a reset of the meter is required and then press  to confirm.
7. At this point the meter finishes SETUP menu and switches off.

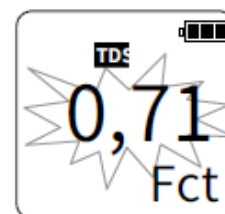

**Note:** To skip the changing of the value simply confirm the flashing value with  key, the meter will go to the next Parameter.

## MEASUREMENT



Rinse the electrode with distilled water or sample prior to start measurement.

Fill the measuring cap with sample, switch on the meter and immerse the Tester in sample and wait for stability, when stability icon appears on display take the reading.

**During measurement make sure that pH electrode membrane is free from air bubbles, and that there is not any air bubble around or between conductivity sensor.**

## Calibration procedure

### CONDUCTIVITY (COND1)

1. Power ON the meter by pressing the  key.
2. Rinse the probe with distilled water.
3. Immerse the probe in the calibration solution (1413 $\mu$ S or 12.88 mS), wait for stability.
4. Press **CAL** key.
5. The meter will start calibration procedure and will recognise automatically the standard used.
6. When calibration is stable press  to confirm and complete the calibration.
7. The standard value will flash for 3 times and then the meter will go into the measurement mode.
8. If the 2nd point calibration is required then rinse the probe with distilled water and immerse in the second standard solution (1413 $\mu$ S or 12.88 mS), wait for stability.
9. Repeat the points 4 to 7.
10. The calibration process is completed and the meter is ready to use.

**Note:** Anytime press  key to abort and exit from calibration procedure.



- Reading based on theoretical cell value C=1
- Standard solution

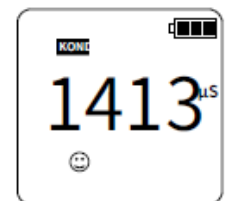
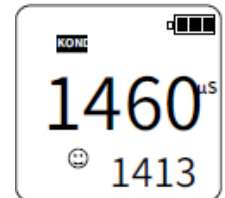
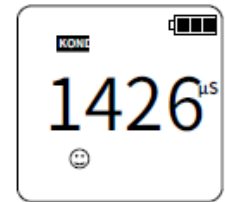



### TDS (COND 1)

When the meter is set to read TDS (see Paragraph "Setup Menu" at page 5), then the calibration is done on TDS with 1 or 2 points.

**The calibration procedure for TDS is the same as for conductivity.**

### PH (PH 1)

1. Power ON the meter by pressing the  key.
2. Rinse the electrode with distilled water.
3. Immerse the electrode in the 1st buffer solution pH7.0 and wait for stability.
4. Press **CAL** key.
5. The meter will start calibration procedure and will recognise automatically the standard used.
6. When calibration is stable press  to confirm and complete the calibration.
7. The standard value will flash for 3 times and then the meter will ask for next point for calibration. If only 1-point calibration is required then press  to finish and exit.
8. If the 2nd point calibration is required then rinse the electrode with distilled water and immerse in pH4.0 or pH10.0, wait for stability.
9. Repeat the points 4 to 7.
10. The calibration process is completed and the meter is ready to use.

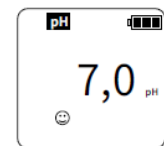
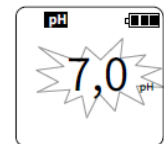
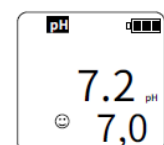
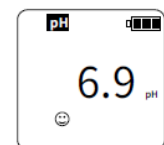

**Note:** Anytime press  key to abort and exit from calibration procedure.

**Note 2:** When the first point calibration is confirmed (point 7) if the sensor is not removed from the buffer solution, the instrument may give wrong buffer error.



## pX 4 / pH 5-Food / ORP 5 / Cond 5 / PC 5 / PC 6

### POWER ON

Press key once, the meter will switch On and performs a test of 3 colours backlight display and then show all the segments active for 2 sec.

Then it will display the following:

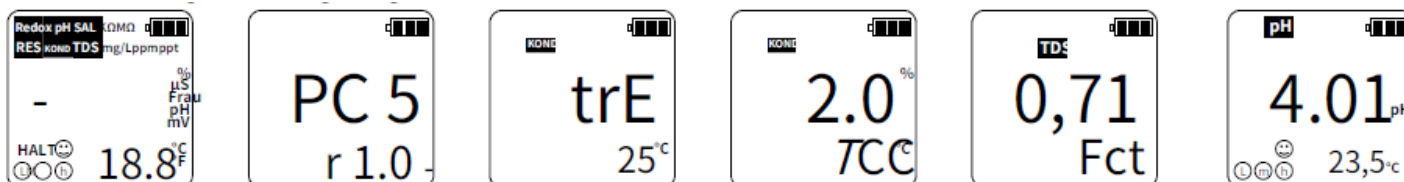

### SETUP MENU FOR PX4 / PH5-FOOD / ORP5 / COND5 / PC5 / PC6

1. With meter switched off, press and hold **CAL** key and press key once..
2. The meter will switch on with all the segments active, release **CAL** key, the meter will go into the Setup menu (green backlight during setup).
3. Press key to select the parameter to be changed between:

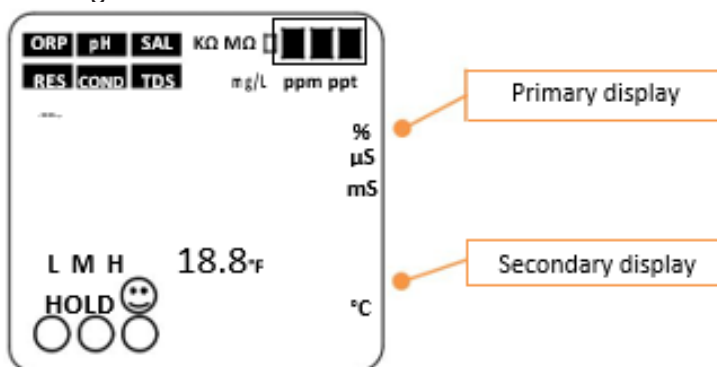

Function	Primary display	Secondary display	Default value
Temperature unit (°C/°F)	T. u.	-	°C
Reference temperature for conductivity	trE	20 - 25 °C	25°C
Coefficient for temperature compensation	0 - 4 %/°C	tCC	1,91
TDS Factor	0,40 - 1,00	Fct	0,71
Reset to factory default	Nein - Ja	rSt	Nein

4. Press to enable the value changing of the selected parameter.
5. The value of selected parameter will start flashing.
6. Press to change the value and then press to confirm.
7. The value stops flashing.
8. Press to select other parameters or press **ESC** to exit the setup menu.

**Note:** Any time press **ESC** key to exit from SETUP menu.

### MEASUREMENT



Rinse the electrode with distilled water or sample prior to start measurement.

Fill the measuring cap with sample, switch on the meter with and press **MODE** key to select desired parameter to be measured (green backlight during measurement). Immerse the Tester in sample and wait for stability, when stability icon appears on display take the reading.

**During measurement make sure that pH electrode is free from air bubbles, and that there isn't any air bubble around or between conductivity sensor.**

## Calibration procedure

### CONDUCTIVITY (COND5 / PC5 / PC6)

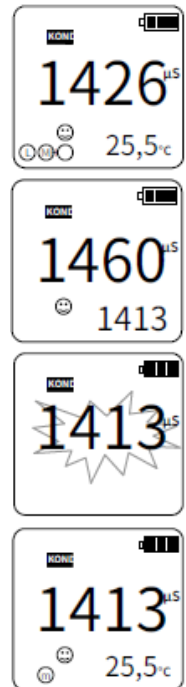

1. Power ON the meter by pressing the  key..
2. Rinse the probe with distilled water.
3. Immerse the probe in the calibration solution (84 $\mu$ S or 1413 $\mu$ S or 12.88mS), wait for stability.
4. Press **CAL** key, (blue backlight during calibration).
5. The meter will start calibration procedure and will recognise automatically the standard used.
6. When calibration is stable press  to confirm and complete the calibration.
7. The standard value will flash for 3 times and then the meter will go into the measurement mode.
8. If the 2nd point calibration is required then rinse the electrode with distilled water and immerse in the 2nd Standard, wait for stability.
9. Repeat the points 4 to 7.
10. If the 3rd point calibration is required then rinse the electrode with distilled water and immerse in the 3rd Standard, wait for stability.
11. Repeat the points 4 to 7.
12. The calibration process is completed and the meter is ready to use.



**Note:** Anytime press **ESC** key to abort and exit from calibration procedure.

**Note 2:** In case multipoint calibration is performed it is better to start from the lower value standard first and then go increasing.

### PH (PX4 / PH5 / PC5 / PC6)

1. Power ON the meter by pressing the  key.
2. Rinse the electrode with distilled water.
3. Immerse the electrode in the 1st buffer solution pH7.00 and wait for stability.
4. Press **CAL** key (blue backlight during calibration).
5. The meter will start calibration procedure and will recognise automatically the standard used.
6. When calibration is stable, press  to confirm and complete the calibration.
7. The standard value will flash for 3 times and then the meter will ask for next point for calibration. If only 1-point calibration is required then press  to finish and exist.
8. If the 2nd point calibration is required then rinse the electrode with distilled water and immerse in pH4.01 or pH10.01, wait for stability, otherwise press **ESC** to finish and exit.
9. Repeat the points 4 to 7.
10. If the 3rd point calibration is required then rinse the electrode with distilled water and immerse in the last buffer, wait for stability, otherwise press **ESC** to finish and exit.
11. Repeat the points 4 to 7.
12. The calibration process is completed and the meter is ready to use.

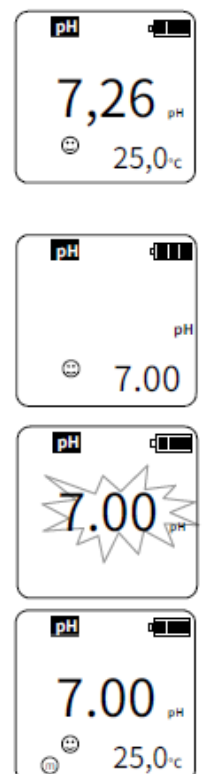

**Note:** Anytime press **ESC** key to abort and exit from calibration procedure.

**ORP (PX4 / ORP5 / PC6)**

1. Switch on the instrument by pressing the  key .
2. Rinse the electrode with distilled water and pat dry gently.
3. Immerse the electrode in the available Redox solution (es: 475 mV); wait for the stability.
4. Press **CAL** button (LED Blu backlight).
5. The instrument enters calibration mode and recognizes the Redox solution, with a certain degree of uncertainty.
6. At the center of the display, the value flashes, in demonstration of the possibility, by the user, to adjust this value by +/- 75 mV compared to what is shown on the display during calibration. Make this operation, keep pressing **MODE** button. Initially the value will move by units, then by tens.

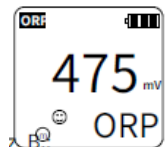
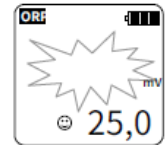

**Note:** The value will only move upwards. If the initial value on the display is higher than the required one (ex: 490 mV with respect to the 475 mV buffer), keep pressing **MODE** until the value becomes lower than the desired (-75 mV with respect to the value shown on the display); at that point it will be possible to reach the desired value by keeping **MODE** pressed.

7. Press  to confirm and complete calibration.
8. Calibration is complete and the instrument automatically returns to measuring mode.

**Note:** Press  at any time to exit calibration.

**POWER OFF**

To turn off the meter press  key for 3 seconds, the meter will switch off. The instrument cannot be switched off during calibration.

**SENSOR MAINTENANCE**

After long time dry storage, put and leave the probe in storage solution (or pH 4) for at least 30 minutes to reactivate the sensor.

**Conductivity 1 - Conductivity 5:**

- Store the sensor dry after each use, once rinsed with distilled water.
- Never touch conductivity probe with paper or any tools (especially the internal part); for cleaning purpose only rinse with distilled water. If touched the probe may damage.

**pH1 – pH4 - pH5 – pH5 Food – ORP5 – PC5 – PC6:**

- Rinse the probe with distilled water before each use.
- Store the sensor into STORAGE Solution (or pH 4) after each use, once rinsed with distilled water.
- Never store pH sensor in distilled water!!!

## REPLACEMENT OF SENSOR



Tester 4, 5 and 6 series have replacement sensors which can be replaced in case it expires or damages.

1. To replace the sensor unscrew the dial in anti-clock wise.
2. Pull out sensor from unit body.
3. Put a new sensor by correctly matching the sign of dent.
4. Be sure that all the gaskets are good and in correct position.
5. Screw the dial tightly.

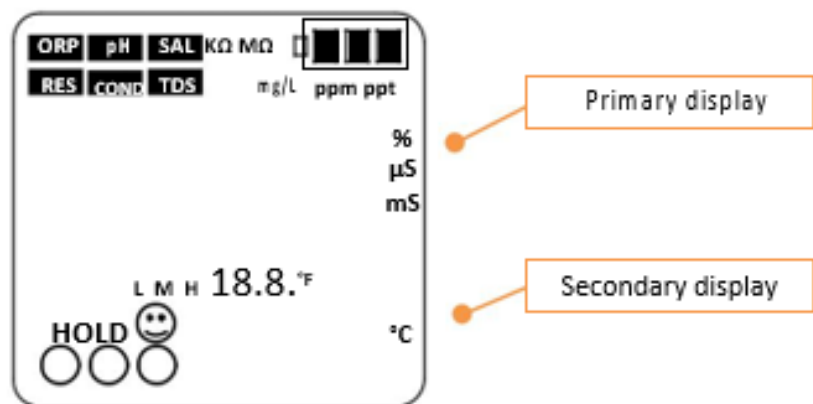
## SETUP MENU FUNCTIONS FOR ALL TESTERS



Function	pH 1	Conductivity	pX4 / pH 5 / ORP 5	Conductivity 5	PC 5 / PC 6	Reset
COND / TDS selection	-	-	-	Yes	Yes	-
TDS factor	-	0,40 - 1,00	-	0,40 - 1,00	0,40 - 1,00	0,71
°C / °F	Yes, nv	Yes, nv	Yes	Yes	Yes	°C
T ref for COND	-	25 °C	-	20 / 25 °C	20 / 25 °C	25 °C
T coefficient	-	1,91 %	-	0 - 4,00 % / °C	0 - 4 % / °C	1,91 %
Reset	Yes	Yes	Yes	Yes	Yes	/

Error	Contents	Checking
Er 1	Wrong pH buffer solution or the recognition of calibration solution out of range.	1. Check whether buffer solution is correct. 2. Check whether the meter connects the electrode well. 3. Check whether the electrode is damaged.
Er 2	Press  key when measuring value is not stable during calibration.	Press  key when the icon appears.
Er 3	During calibration, the measuring value is not stable for $\geq 3$ min.	1. Check whether there are bubbles in glass bulb. 2. Replace with new electrode.
Er 4	Electrode zero electric potential out of range (<-60mV or >60mV)	1. Check whether there are bubbles in glass bulb.
Er 5	Elektrodensteilheit außerhalb des Bereichs. (<85% oder >110%)	2. Check whether pH buffer solution is correct. 3. Replace with new pH electrode.
Er 6	pH measuring range out of range (<0.00 pH or >14.00pH) 1 Series (<-2.00 pH or >16.00pH) 5 Series	1. Check whether the electrode is suspended. 2. Check whether the meter connects the electrode well. 3. Check whether the electrode is damaged.

## DISPOSAL OF ELECTRONIC DEVICES

The electrical and electronic equipment marked with this symbol cannot be disposed of in public landfills.

According to the UE Directive 2002/96/EC, the European users of electrical and electronic equipment can return it to the dealer or manufacturer upon purchase of a new one.

The illegal disposal of electrical and electronic equipment is punished with an administrative fine.



## SAFETY INSTRUCTIONS

- Read this instruction manual carefully before using your new tester.
- The membrane of pH electrode is made of glass and can be danger in case it breaks. To avoid damage check the electrode tip after each measurements.
- Replace all batteries together with same type.
- The manufacturer of these instruments cannot be held responsible for any improper use.
- Verification of the measuring results is the responsibility of the operator and the manufacturer does not respond to any direct or indirect damage occurred while using this instrument.